

科技创伟海 智造赢未来
TECHNOLOGY CREATE WEIHAI
WISDOW WIN FUTURE

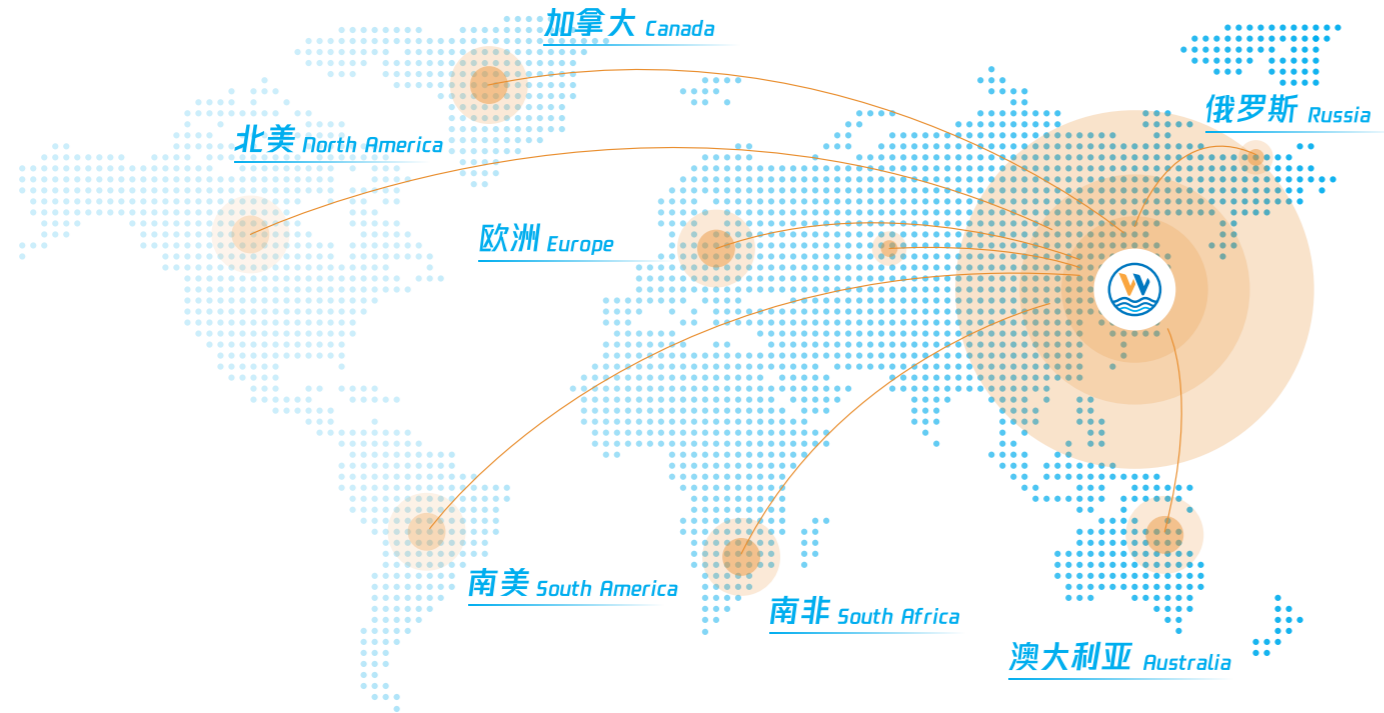

伟海销售体系

伟海科技自创立以来，建立了完善的售前、售中、售后服务体系，遍布全国200城，协同互补高效维护区域客户。

营销网点遍布

德国、英国、美国、加拿大、俄罗斯、澳大利亚、马来西亚、新加坡、以色列、韩国、日本、印度、巴基斯坦、土耳其、伊朗等。

青岛伟海金属科技有限公司
QINGDAO WEIHAI METAL TECHNOLOGY CO.LTD

地址：山东省青岛市黄岛区海西路2688号
服务热线：400-613-7555

Address: No.2688 Haixi Road, Huangdao District, Qingdao, Shandong
Number: 400-613-7555



伟海科技
WEIHAI TECH

产品目录书 PRODUCT CATALOG



科技创伟海 智造赢未来

● Flower Cart ● Tool Shelf ● Caster Wheel

科技创伟海

智造赢未来

TECHNOLOGY CREATE
THE FUTURE



科技创伟海，智造赢未来！

伟海科技以技术为核心，以品质为生命，不断创新研发，花卉车、货架、脚轮多方面发展。将生产智能化，数据化，科技化，成为智能物流设备的实力生产基地，在国家开发、共享的号召下，实行厂商一体化的营运模式，搭建全球品牌战略合作伙伴的大平台。

Weihai Technology takes technology as the core, quality as the life, and constantly innovates and develops in many aspects, such as flower car, shelf and caster. Make the production intelligent, data-based, scientific and technological, and become the strength production base of intelligent logistics equipment. Under the call of national development and sharing, implement the integrated operation mode of manufacturers, and build a large platform for global brand strategic partners.



Group Profile

集团简介

青岛建墩建设集团，是青岛市黄岛区知名企业，本集团实力雄厚，诚信务实本着合竞共赢，合争共达的思想理念，与社会各界携手努力，共创辉煌！

本集团旗下企业：青岛建墩集团工程有限公司、青岛建墩集团市政有限公司、青岛建墩集团地基基础有限公司、青岛伟海金属科技有限公司、青岛卫姜水产育苗有限公司、青岛泽鸿建筑劳务有限公司、青岛宝嘉建材有限公司等企业。

资质证书

建筑业资质证书



建筑业资质证书



安全生产许可证

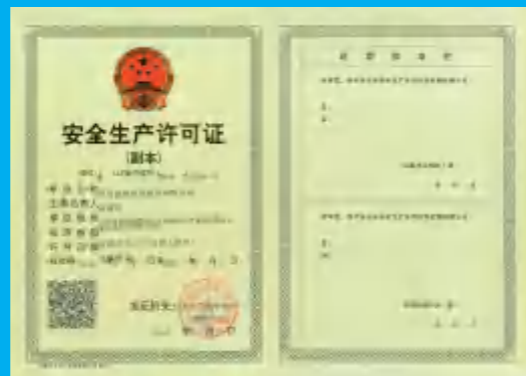

Chairman Message

董事长寄语



姜墩伟

青岛建墩集团董事长

Chairman of Qingdao Jiandun Group

以科技创伟海为企业的发展目标，
智造赢未来作为企业的发展方向，实力打造新一代脚轮领军企业。

Taking science and technology as the development goal of the enterprise.
Smart manufacturing wins the future as the development direction of the enterprise.Strength to build a new generation of caster leading enterprises.



和争共达 合竞共赢

Strive for peace
Win win cooperation and competition

智造动力

WISDOM CREATES POWER

我们开拓行业智能化发展，为科技创新注入新动力，
承诺为客户提供值得信赖的脚轮产品解决方案。

We have opened up the intelligent development of the industry , Firmly injected
new impetus into scientific and technological innovation,

Commitment to provide customers with reliable caster product solutions.

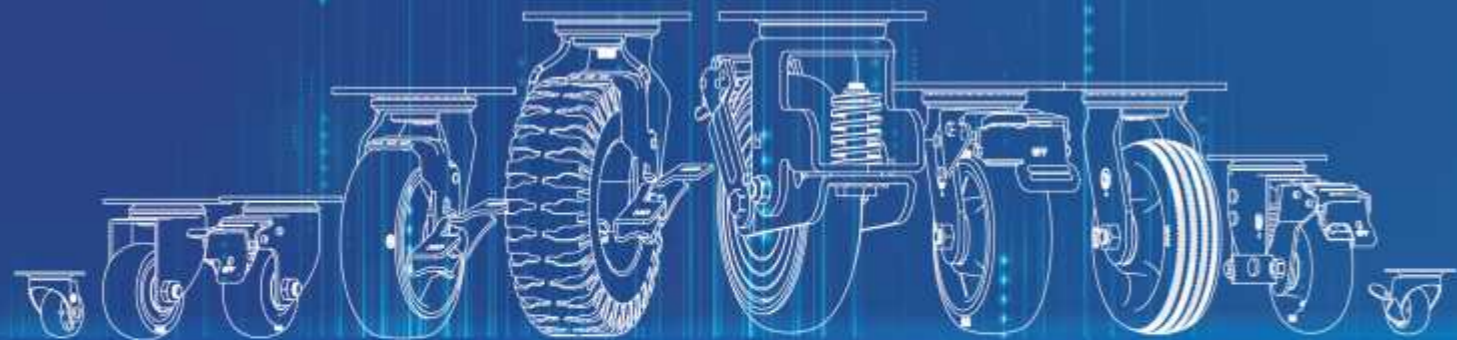

CONTENTS

目录

智造伟海 INTELLIGENT MADE 02

• 关于伟海	02	• 智造实力	03
• MES系统	08	• 技术研发	10

主打产品 KEY PRODUCTS 12

• 花卉车	12	• 货架	18
• 脚轮			
重型系列	26	中型系列	36
气胎轮系列	56	美式地刹器	60

商务洽谈 Business Negotiation 63



Intelligence Power

智造实力

Automatic Forming Equipment of Flower Cart Post 花卉车立柱自动成型设备



伟海科技花卉车立柱自动成型设备采用一套数控液压切断装置，配合高精密冲床龙门式成型机，完成全部冲孔与成型工艺，生产效率更高效，冲孔更稳定，大大节省了人工提高了安全性。

Weihai Technology Flower cart post automatic forming equipment uses a set of numerical control hydraulic cutting device, with high precision punch gantry forming machine, complete all punching and forming process, more efficient production efficiency, more stable punching, greatly saving labor, improving safety.



About Weihai

关于伟海



国家高新技术企业
National High-Tech Enterprise

青岛伟海金属科技有限公司，成立于2015年，是国家重点扶持的高新技术企业，专业从事花架车，货架，脚轮等配套产品的生产与出口，拥有三十多种产品，十余种国家专利，于2016年荣获青岛西海岸“青蓝汇”创新创业大赛一等奖。脚轮国内销量领先，花卉车产品远销欧美各国，占欧洲市场份额的80%。

公司占地32000平方米拥有配套现代化生产厂区2个，拥有中国最先进的数字化注塑车间，高素质专业人才，从产品开发，模具设计制造形成一整套完整的科学工艺体系。并运用优良的工装设备，先进的测试手段，科学的质量管理体系，为生产优质的产品提供了可靠的保证。

自公司成立以来，公司大胆创新，不断开拓，与时俱进，不拘一格，广揽人才，为公司发展奠定了坚实的基础，秉承“以质量求生存，以信誉求发展”的信念，赢得广大客户的信赖与合作。

科技创伟海，智造赢未来。



Imported Manipulator - High Precision Tooling 进口机械手-高精度工装



伟海科技花卉车采用进口机械手配合高精度工装，全自动焊接，大大保证了产品品质，获国外客商一直好评。

Weihai Technology flower cart adopts imported manipulator with high precision tooling and automatic welding, which greatly ensures the product quality and has been praised by foreign customers.



Injection Workshop 注塑车间



自动化车间

脚轮单轮的生产车间，采用全自动中央供料系统，全程机械手取件，传送带传送，属于全自动化车间。

该车间采用数据化程控体系，将生产过程转变为流程化，数据化，智能化，将制造变智造！此车间人工降耗37%，原材料减耗25%，能耗节省30%！

Caster single wheel production workshop, using automatic central feeding system, the whole process of mechanical hand pick-up, conveyor belt transmission, belongs to the fully automated workshop. The workshop adopts the data-based program control system, which transforms the production process into process, data and intelligence, and transforms the manufacturing into intelligent manufacturing! This workshop reduces labor consumption by 37%, raw material consumption by 25%, and energy consumption by 30%!



Stamping Workshop 冲压车间

脚轮五金支架生产车间，采用大型冲床与送料器配合，生产效率大幅度提升。

同时，区别于传统行业的生产方式，全程使用传送带与提升机，产品与废料进行传送分离，让冲压生产效能更高，生产效能提高21%，安全性提升75%！



Pouring Workshop 浇注车间



脚轮铁芯、钢芯聚氨酯单轮的生产车间，此车间更改了设备生产工艺，增加了入料的防飞溅系统，浇注入料平衡系统，降低了30%的废品率。

配合双组份的高能配方，让原材料性能发挥到极致，降低了电耗60%，增加循环工艺生产线，提高了35%的产能！

Assembly Workshop 装配车间



脚轮成品的组装车间，所有支架铆接，单轮装轴承均采用了机械助力，节省人工20%，提升了产品出货速度，单轮与支架的组装，也主要是运用了机械自动铆合，区别于传统行业的人工气枪拧螺丝螺母，对螺丝螺母的损伤很小，标准化、精准化程度更高。



下一步将进行自动装配线的设备工艺组合，加上自动送料的传送带与产品入框分拣的系统，逐步将装配的人工化转换成自动化，机械化，智能化，实现全行业首个自动化无人装配车间。



MES Management System

MES管理系统



MES数据化管理系统

实现以日为单位的业务：据监控（参数设定、状态显示、全流程的品质把控等）

自动生成告警信息，自动分析账单数据逻辑关系，并给出可信度评价。

减少流失，降低风险，提高生产效率。

MES DATA MANAGEMENT SYSTEM

Daily business: data monitoring (parameter setting, status display, quality control of the whole process, etc.)

It can automatically generate alarm information, automatically analyze the logical relationship of bill data, and give credibility evaluation.

Reduce the loss, reduce the risk and improve the production efficiency.

Technology R & D 技术研发



青岛市中小企业专精特新产品（技术）证书



高新技术企业证书



质量管理体系认证证书



环境管理体系认证证书



职业健康安全体系认证证书

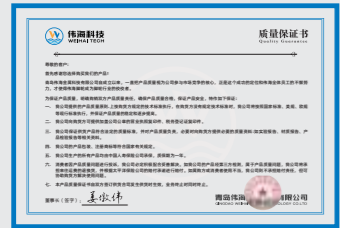

伟海科技质量保证书



中国人寿保险承保



美国工业标准



英国工业标准



日本工业标准



中国工业标准



德国工业标准

技术是核心，品质是生命！

- 盐雾测试：国家级 6 级
- 冲击实验：每次 1750 KG 的冲击力
- 硬度：按照各国标准测试均达标
- 水平行走：每个产品最少 10 万米，时速 4 公里/小时
- 刹车性能：每个产品，连续刹车 1.5 万次，无性能疲劳形变
- 耐磨：每个产品在 10 个小时的连续摩擦下，未出现轮面形变和尺寸超差

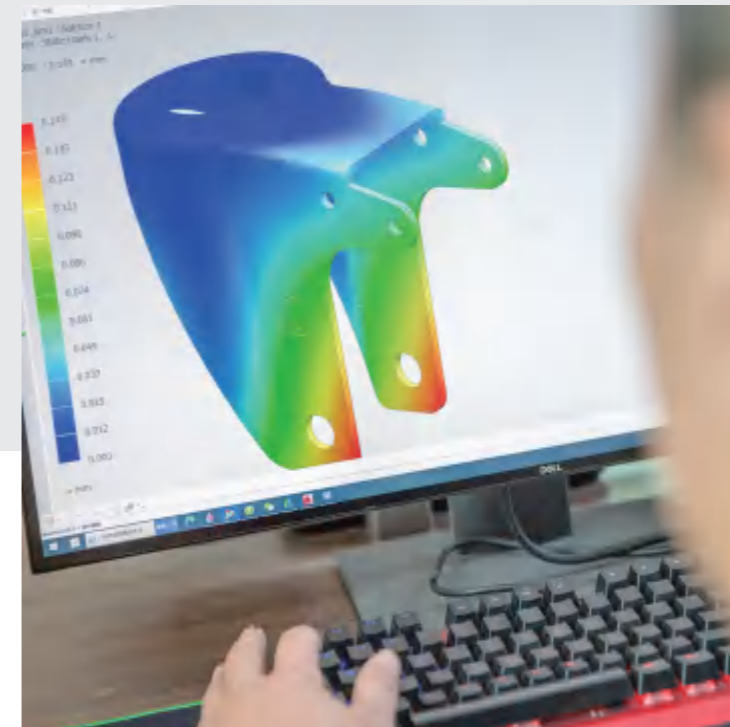

每一个生产周期必检，每一道工序必检！

伟海科技的脚轮检测标准是根据国际脚轮标准（日本标准、英国标准、美国标准、德国标准）和国家脚轮标准（中国GB标准）进行的综合性测试。

我们定制的实验设备通过上海检测机构进行检测，完全符合脚轮测试的要求。所以，本公司出具的检测报告，符合国家要求。

INTELLIGENT POWER

智造动力

花卉车 FLOWER CART

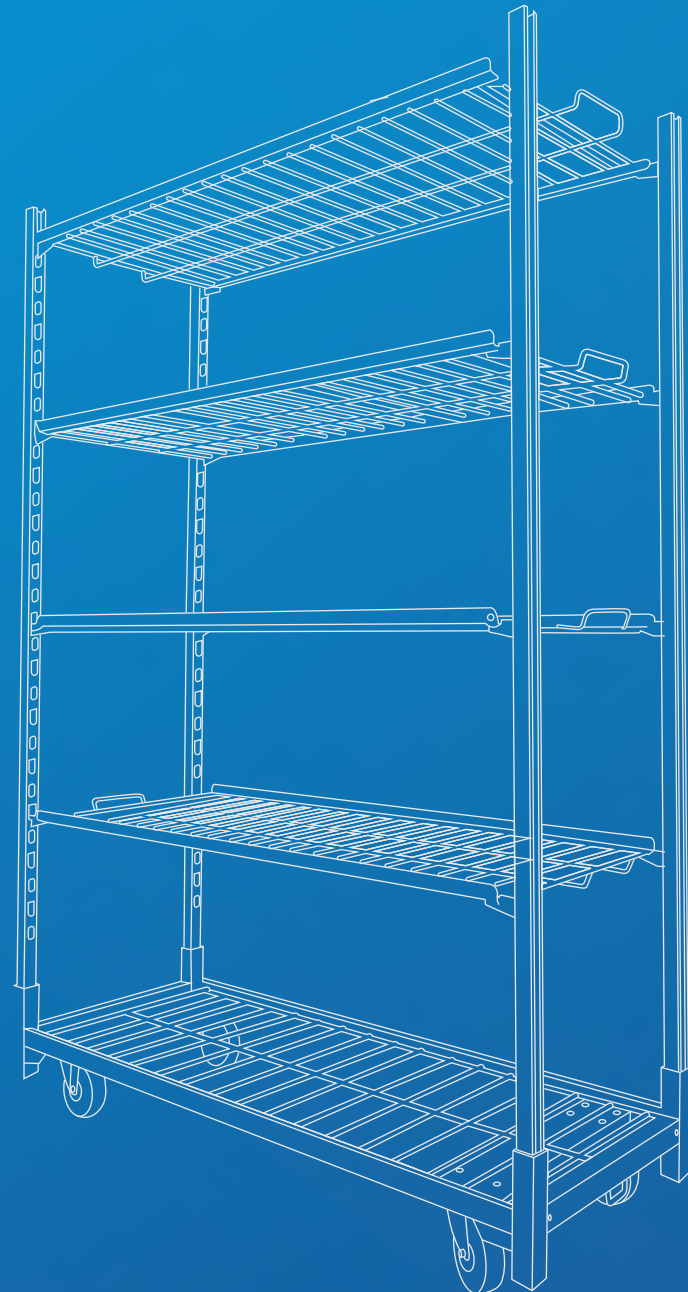

花卉车 FLOWER CART



产品信息 (单位: mm)

基本尺寸	1350*565	715 *565	675 *565	810*6 10	1430*565	1892 *565
可选材质	Plywood	Plastic	Mesh Wire	Pre-galvanized plate	PVC	Aluminium Plate Expanded Mesh
表面处理	Cold Galvanized	Hot Dipped Galvanized			Powder Coating	
脚轮	5"PP	Nylon			TPR	

花卉车 FLOWER CART SHELF



层板 SHELF

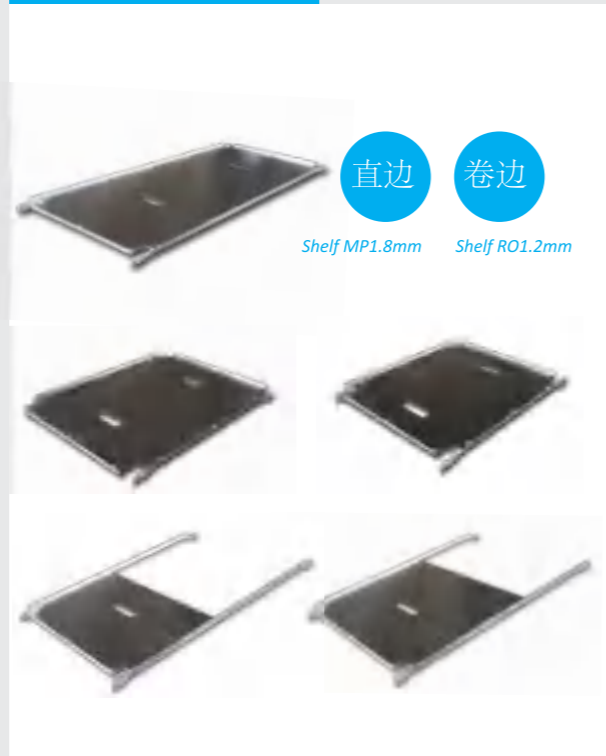

产品信息 (单位: mm)

尺寸	1350*565	715 *565	675 *565	810*6 10	1430*565	1892 *565	
可选材质	Plywood	Plastic	Mesh Wire	Pre-galvanized plate	PVC	Aluminium Plate	Expanded Mesh
表面处理	Cold Galvanized	Hot Dipped Galvanized			Powder Coating		
半架子 (胶合板)	500mm			700mm			

花卉车 FLOWER CART



层板和牵引系统 SHELF & PART

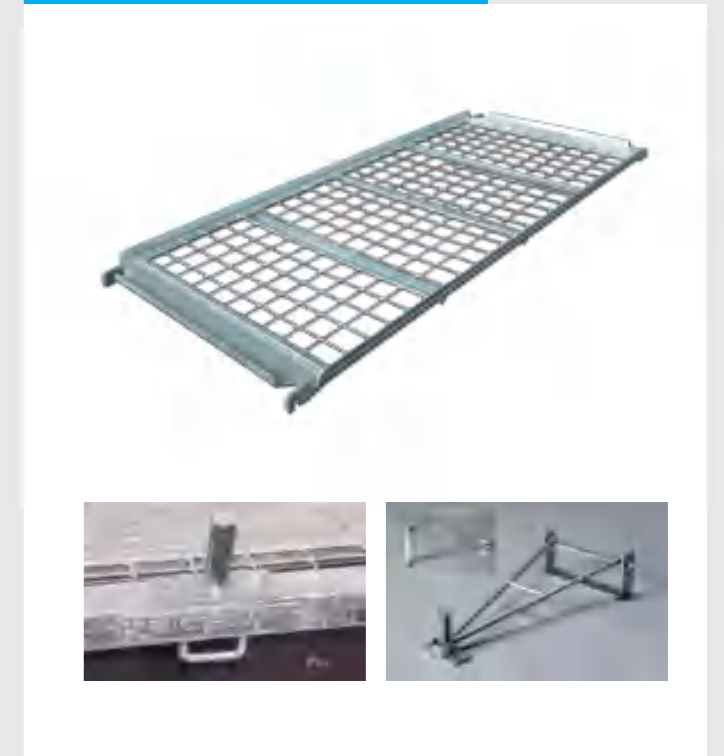

产品信息 (单位: mm)

尺寸	1350*565	715 *565	675 *565	810*6 10	1430*565	1892 *565	
可选材质	Plywood	Plastic	Mesh Wire	Pre-galvanized plate	PVC	Aluminium Plate	Expanded Mesh
表面处理	Cold Galvanized	Hot Dipped Galvanized			Powder Coating		
脚轮	5"PP			Nylon		TPR	

铝花卉车 MAESTRO CONTAINER



铝花卉车 MAESTRO SHELF

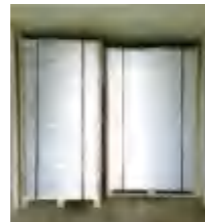

产品信息 (单位: mm)

尺寸	1310* 1020* 1900mm
重量	34.4kg
表面处理	Hot Zinc (Steel /Aluminium)
轮	HD Rubber Wheels & Pulling Kit & Barcode Attachment Mounting
装载能力	600kg, Max

产品信息 (单位: mm)

尺寸	1270* 1010mm
材料	Full Aluminum
钩	6mm hook aluminum
装载能力	200kg max
重量	7.2kg

延伸件 POST & EXTENSION



延伸件 EXTENSION



Extension Information(unit:mm)

Size	390mm	660mm
Thickness	0.8	1.0 1.2
Material	Galvanize steel	



产品信息 (单位: mm)

基本尺寸	1950mm	1800mm	1775mm	1650mm	1150mm	770mm
表面处理	Cold Galvanized		Hot Dipped Galvanized		Powder Coating	
厚度	1.8	2	2.5	3		

INTELLIGENT POWER

智造动力

货架 SHELF

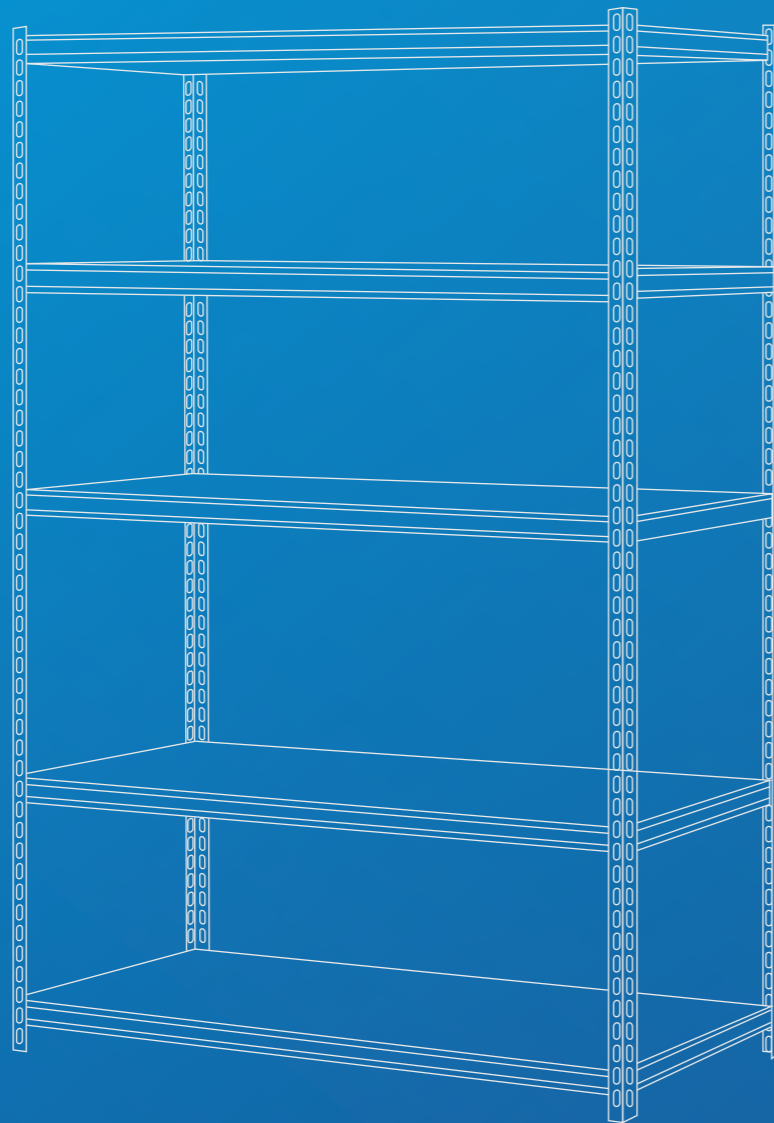

货架 HEAVY DUTY SHELF T21A

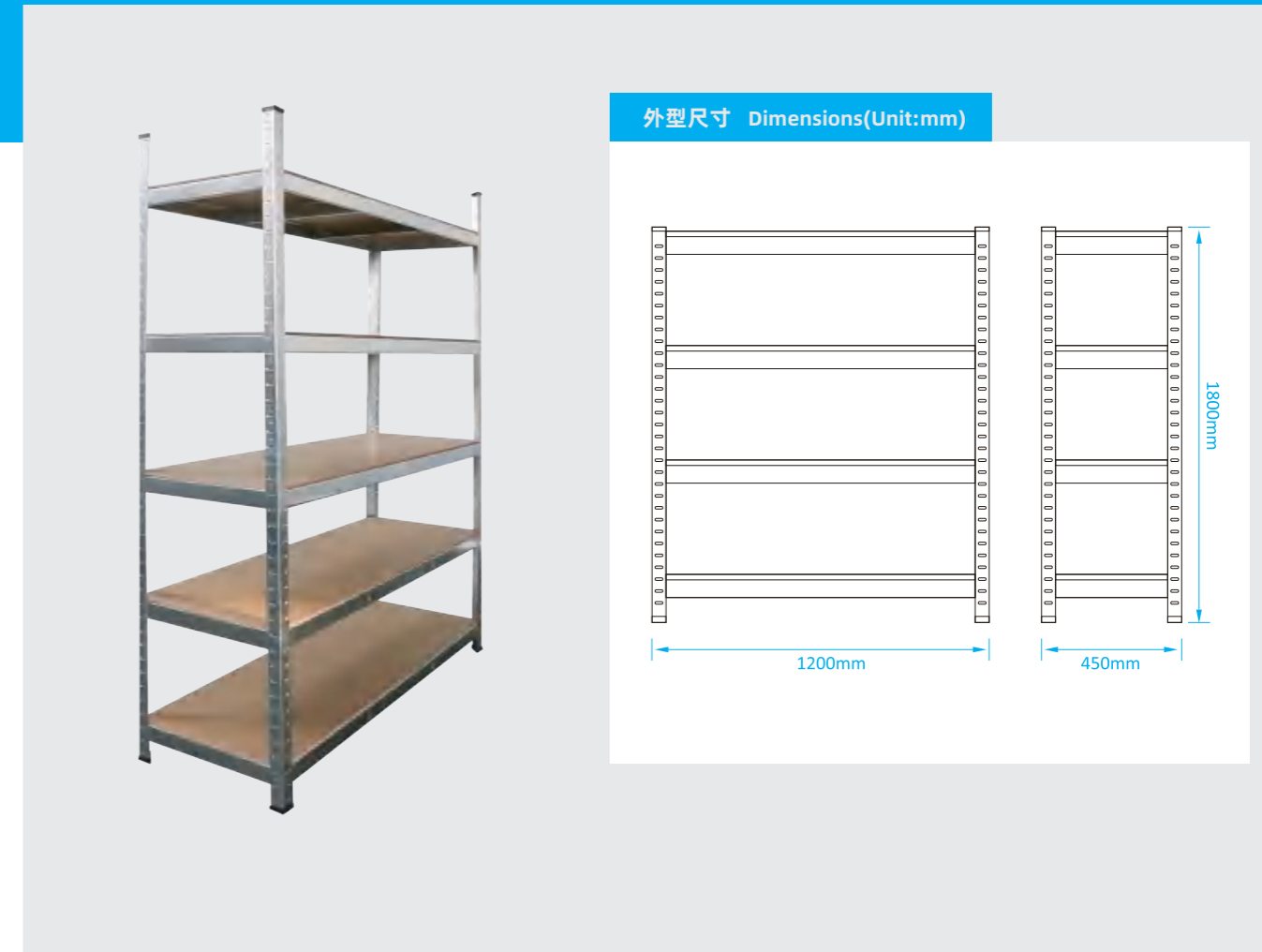

产品信息 (单位: mm)

Product Information(unit:mm)			
Model	T21A	Middle support	2 pcs per layer
Material	Galvanized steel sheet	Metal Thickness	1.2mm
Height	1800mm	MDF	6.8mm
Length	1200mm	Edge	Curled or straight
Width	450mm	Finish	Galvanized or painting
Clapboard Material	MDF	Packing	1 pcs / carton
Layer	4 layer or 5 layer	Net Weight	29kg-32kg
Load Capacity	265KG per layer		

货架 TOOL SHELF T20A

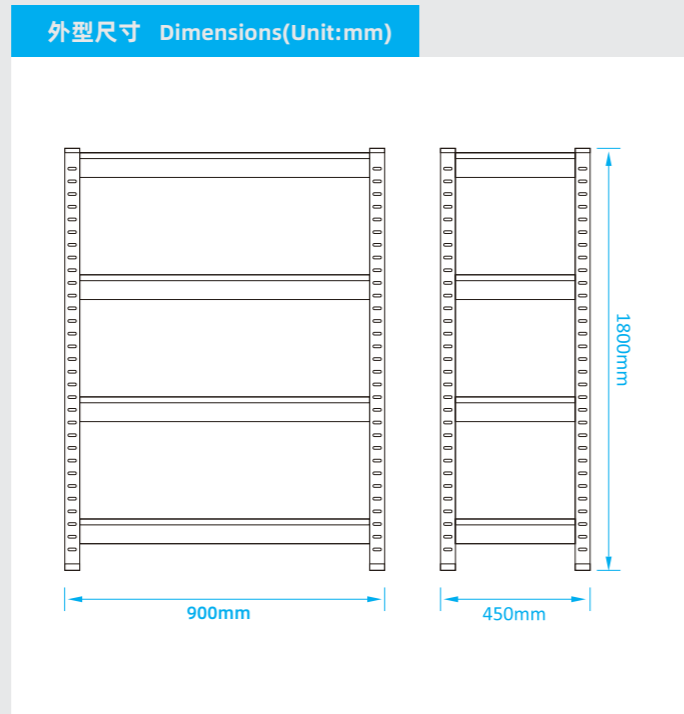

货架 TOOL SHELF T40

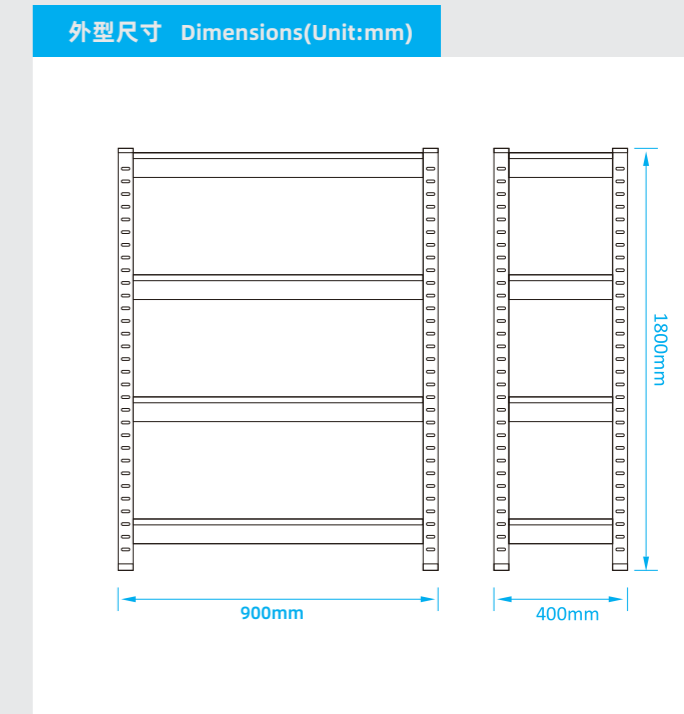

产品信息 (单位: mm)

Product Information(unit:mm)			
Model	T20A	Middle support	without
Material	Galvanized steel sheet	Metal Thickness	1.2mm
Height	1800mm	MDF	6.8mm
Length	900mm	Edge	20kg- 23kg
Width	450mm	Finish	Curled or straight
Clapboard Material	MDF	Packing	Galvanized or painting
Layer	4 layer or 5 layer	Net Weight	1 pcs /shrink
Load Capacity	265KG per layer		

产品信息 (单位: mm)

Product Information(unit:mm)			
Model	T40	Middle support	1 pcs per layer
Material	Galvanized steel sheet	Metal Thickness	0.7mm
Height	1800mm	MDF	4mm or 5mm
Length	900mm	Net weight	13.14 kg -15.12kg
Width	400mm	Edge	Curled or straight
Clapboard Material	MDF	Finish	Galvanized or painting
Layer	4 layer or 5 layer	Packing	1 pcs / shrink
Load Capacity	170KG per layer		

货架 TOOL SHELF T32



外型尺寸 Dimensions(Unit:mm)

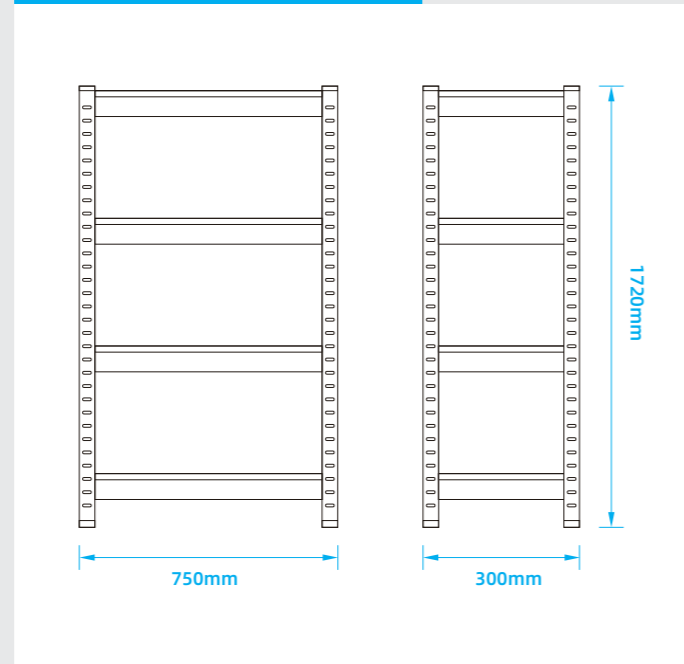

产品信息 (单位: mm)

Product Information(unit:mm)			
Model	T32	Middle support	without
Material	Galvanized steel sheet	Metal Thickness	0.7mm
Height	1720mm	MDF	4mm or 5mm
Length	750mm	Edge	10.80kg- 11.50kg
Width	300mm	Finish	Curled or straight
Clapboard Material	MDF	Packing	Galvanized or painting
Layer	4 layer or 5 layer	Net Weight	1 pcs /shrink
Load Capacity	75KG per layer		

货架 PALLET RACK 810x610



外型尺寸 Dimensions(Unit:mm)

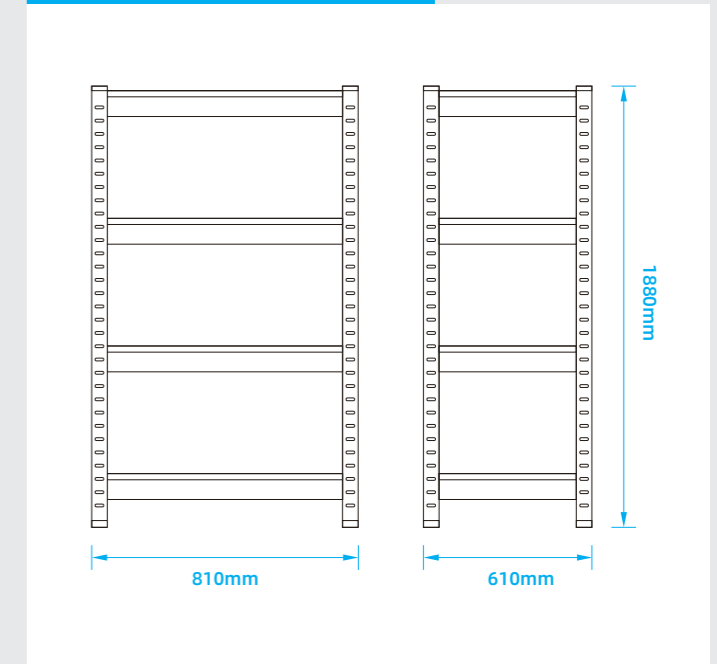

产品信息 (单位: mm)

Product Information(unit:mm)			
Model	810x610	Middle support	1 pcs or without
Material	Galvanized steel sheet	Layer	4 layer or 5 layer
Height	1880mm	MDF	4mm or 5mm
Length	810mm	Net weight	17.5 kg -20.2kg
Width	610mm	Edge	straight
Rack	corner tube 1.5mm, length / width support :3.0mm with 1 middle support 24x25/1.8mm	Finish	Galvanized or painting
Clapboard Material	MDF	Packing	1 sets per bundle
Load Capacity	75 kgs per layer		

INTELLIGENT POWER

智造动力

01 02 03 04
重型系列 / 中型系列 / 气胎轮系列 / 美式闭刹器
Heavy / Medium / Pneumatic / American Brake



重型系列 Heavy Series

01

适用于工厂搬运、仓储物流、机械制造等多种行业



Sectional View Animation

产品剖视图

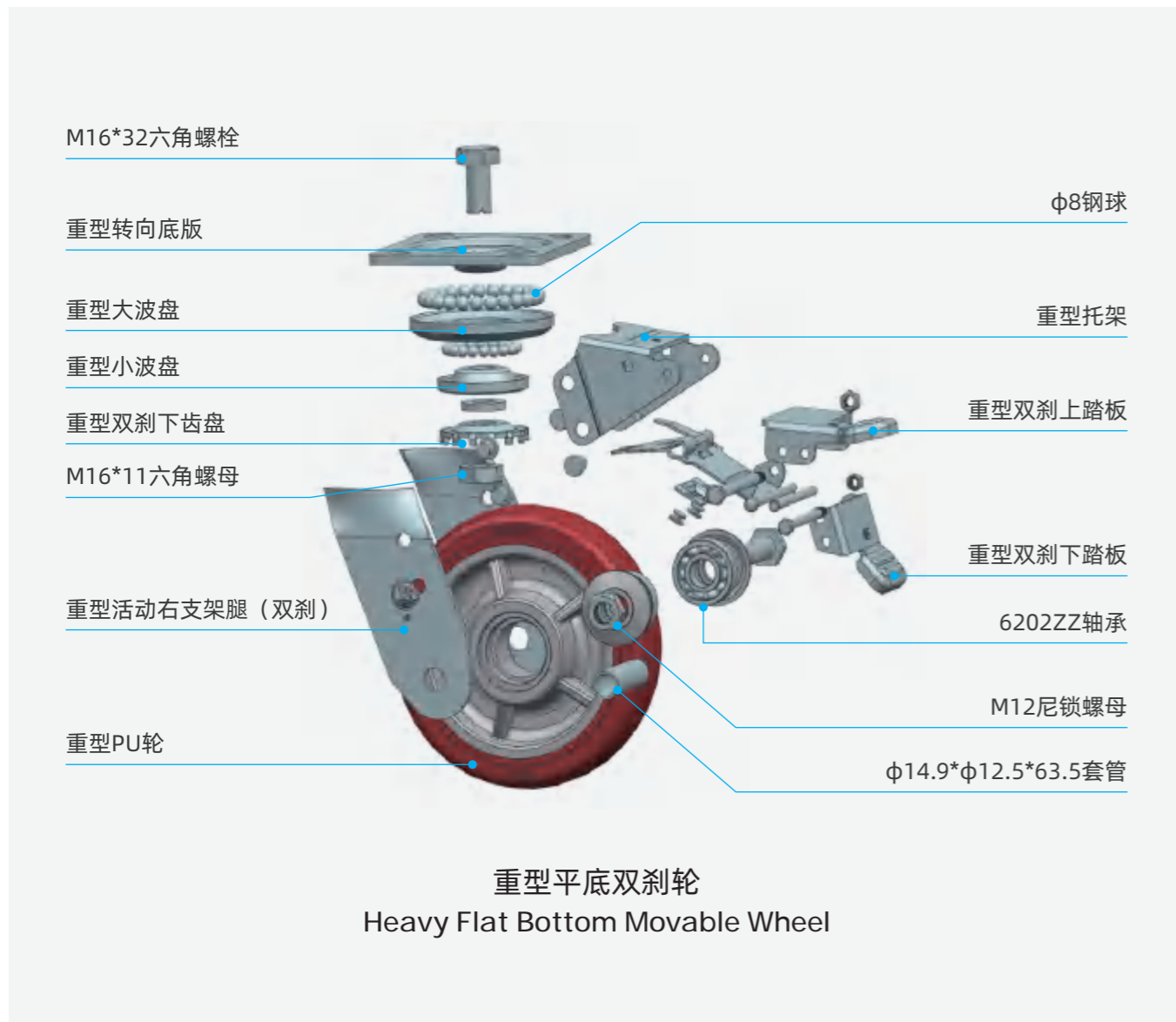

Installation Dimensions

安装尺寸图

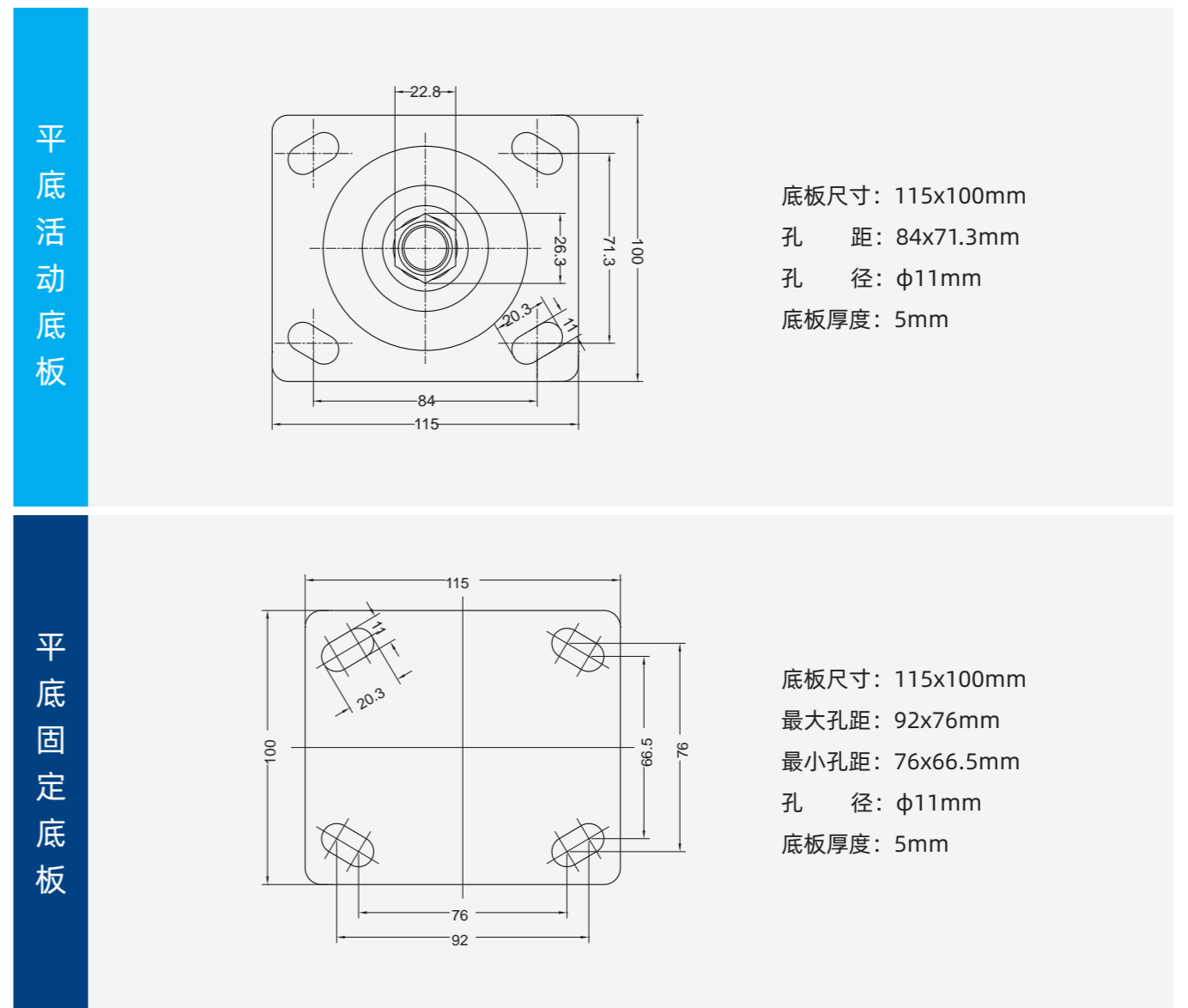

01-1 重型工程 共聚(增韧PP)轮系列

Heavy Series Wheel



单轮剖视
双轴承工程共聚轮



产品特点



PRODUCT TYPE

产品类型

No.

产品编码



支架尺寸



支架开口宽度



轮径



轮宽



净重



安装高度



载重



极限载重



底板规格



转动半径



孔距



孔径



装箱数



装箱尺寸



拖数



托盘尺寸

寸

mm

mm

mm

kg

kg

kg

kg

mm

mm

mm

mm

个

mm

箱

mm



平底活动

100111	4寸	64	100	44	-	143	250	375	115*100	83	84*71.3	11	20	460*260*280	56	100*100
100112	5寸	64	125	44	-	165.5	300	450	115*100	98	84*71.3	11	16	460*260*280	56	100*100
100113	6寸	64	150	44	-	190	380	570	115*100	114	84*71.3	11	12	460*260*280	56	100*100
100114	8寸	64	200	44	-	240.5	450	675	115*100	147	84*71.3	11	8	460*260*280	56	100*100



平底固定

100078	4寸	64	100	44	-	143	250	375	115*100	-	84*71.3	11	20	460*260*280	56	100*100
100079	5寸	64	125	44	-	165.5	300	450	115*100	-	84*71.3	11	16	460*260*280	56	100*100
100080	6寸	64	150	44	-	190	380	570	115*100	-	84*71.3	11	12	460*260*280	56	100*100
100081	8寸	64	200	44	-	240.5	450	675	115*100	-	84*71.3	11	8	460*260*280	56	100*100



平底边刹

100212	4寸	64	100	44	-	143	250	375	115*100	83	84*71.3	11	15	460*260*280	56	100*100
100213	5寸	64	125	44	-	165.5	300	450	115*100	98	84*71.3	11	12	460*260*280	56	100*100
100214	6寸	64	150	44	-	190	380	570	115*100	114	84*71.3	11	8	460*260*280	56	100*100
100215	8寸	64	200	44	-	240.5	450	675	115*100	147	84*71.3	11	6	460*260*280	56	100*100



平底双刹

100171	4寸	64	100	44	-	143	250	375	115*100	83	84*71.3	11	15	460*260*280	56	100*100
100172	5寸	64	125	44	-	165.5	300	450	115*100	98	84*71.3	11	12	460*260*280	56	100*100
100173	6寸	64	150	44	-	190	380	570	115*100	114	84*71.3	11	8	460*260*280	56	100*100
100174	8寸	64	200	44	-	240.5	450	675	115*100	147	84*71.3	11	6	460*260*280	56	100*100

01-2 重型回弹 聚氨酯轮(耐磨配方)轮系列

Heavy Series Wheel



单轮剖视
双轴承聚氨酯轮



产品特点



PRODUCT TYPE

产品类型

No.

产品编码



支架尺寸



支架开口宽度



轮径



轮宽



净重



安装高度



载重



极限载重



底板规格



转动半径



孔距



孔径



装箱数



装箱尺寸



拖数



托盘尺寸

寸

mm

mm

mm

kg

kg

kg

kg

mm

mm

mm

mm

个

mm

箱

mm



平底活动

100115	4寸	64	100	50	-	143	220	330	115*100	83	84*71.3	11	20	460*260*280	56	100*100
100116	5寸	64	125	50	-	165.5	280	420	115*100	98	84*71.3	11	16	460*260*280	56	100*100
100117	6寸	64	150	50	-	190	350	525	115*100	114	84*71.3	11	12	460*260*280	56	100*100
100118	8寸	64	200	50	-	240.5	430	645	115*100	147	84*71.3	11	8	460*260*280	56	100*100



平底固定

100082	4寸	64	100	50	-	143	220	330	115*100	-	84*71.3	11	20	460*260*280	56	100*100
100083	5寸	64	125	50	-	165.5	280	420	115*100	-	84*71.3	11	16	460*260*280	56	100*100
100084	6寸	64	150	50	-	190	350	525	115*100	-	84*71.3	11	12	460*260*280	56	100*100
100085	8寸	64	200	50	-	240.5	430	645	115*100	-	84*71.3	11	8	460*260*280	56	100*100



平底边刹

100216	4寸	64	100	50	-	143	220	330	115*100	83	84*71.3	11	15	460*260*280	56	100*100
100217	5寸	64	125	50	-	165.5	280	420	115*100	98	84*71.3	11	12	460*260*280	56	100*100
100218	6寸	64	150	50	-	190	350	525	115*100	114	84*71.3	11	8	460*260*280	56	100*100
100219	8寸	64	200	50	-	240.5	430	645	115*100	147	84*71.3	11	6	460*260*280	56	100*100



平底双刹

100175	4寸	64	100	50	-	143	220	330	115*100	83	84*71.3	11	15	460*260*280	56	100*100
100176	5寸	64	125	50	-	165.5	280	420	115*100	98	84*71.3	11	12	460*260*280	56	100*100
100177	6寸	64	150	50	-	190	350	525	115*100	114	84*71.3	11	8	460*260*280	56	100*100
100178	8寸	64	200	50	-	240.5	430	645	115*100	147	84*71.3	11	6	460*260*280	56	100*100

01-3 重型塑芯 高分子TPR(Q弹配方)轮系列

Heavy Series Wheel



单轮剖视
双轴承高分子弹性轮



产品特点



PRODUCT TYPE 产品类型	No. 产品编码	支架尺寸 寸	支架开口宽度 mm	轮径 mm	轮宽 mm	净重 kg	安装高度 kg	载重 kg	极限载重 kg	底板规格 mm	转动半径 mm	孔距 mm	孔径 mm	装箱数 个	装箱尺寸 mm	拖数 箱	托盘尺寸 mm
 平底活动	100119	4寸	64	100	50	-	143	170	255	115*100	83	84*71.3	11	20	460*260*280	56	100*100
	100120	5寸	64	125	50	-	165.5	220	330	115*100	98	84*71.3	11	16	460*260*280	56	100*100
	100121	6寸	64	150	50	-	190	280	420	115*100	114	84*71.3	11	12	460*260*280	56	100*100
	100122	8寸	64	200	50	-	240.5	350	525	115*100	147	84*71.3	11	8	460*260*280	56	100*100
 平底固定	100086	4寸	64	100	50	-	143	170	255	115*100	-	84*71.3	11	20	460*260*280	56	100*100
	100087	5寸	64	125	50	-	165.5	220	330	115*100	-	84*71.3	11	16	460*260*280	56	100*100
	100088	6寸	64	150	50	-	190	280	420	115*100	-	84*71.3	11	12	460*260*280	56	100*100
	100089	8寸	64	200	50	-	240.5	350	525	115*100	-	84*71.3	11	8	460*260*280	56	100*100
 平底边刹	100220	4寸	64	100	50	-	143	170	255	115*100	83	84*71.3	11	15	460*260*280	56	100*100
	100221	5寸	64	125	50	-	165.5	220	330	115*100	98	84*71.3	11	12	460*260*280	56	100*100
	100222	6寸	64	150	50	-	190	280	420	115*100	114	84*71.3	11	8	460*260*280	56	100*100
	100223	8寸	64	200	50	-	240.5	350	525	115*100	147	84*71.3	11	6	460*260*280	56	100*100
 平底双刹	100183	4寸	64	100	50	-	143	170	255	115*100	83	84*71.3	11	15	460*260*280	56	100*100
	100184	5寸	64	125	50	-	165.5	220	330	115*100	98	84*71.3	11	12	460*260*280	56	100*100
	100185	6寸	64	150	50	-	190	280	420	115*100	114	84*71.3	11	8	460*260*280	56	100*100
	100186	8寸	64	200	50	-	240.5	350	525	115*100	147	84*71.3	11	6	460*260*280	56	100*100

01-4 重型铁芯 聚氨酯轮系列

Heavy Series Wheel



单轮剖视
双轴承铁芯聚氨酯轮



产品特点



PRODUCT TYPE

产品类型

No.

产品编码



支架尺寸



支架开口宽度



轮径



轮宽



净重



安装高度



载重



极限载重



底板规格



转动半径



孔距



孔径



装箱数



装箱尺寸



拖数



托盘尺寸

寸

mm

mm

mm

kg

kg

kg

kg

mm

mm

mm

mm

个

mm

箱

mm



平底活动

100123	4寸	64	100	50	-	143	270	405	115*100	83	84*71.3	11	20	460*260*280	56	100*100
100124	5寸	64	125	50	-	165.5	320	480	115*100	98	84*71.3	11	16	460*260*280	56	100*100
100125	6寸	64	150	50	-	190	430	645	115*100	114	84*71.3	11	12	460*260*280	56	100*100
100126	8寸	64	200	50	-	240.5	480	720	115*100	147	84*71.3	11	8	460*260*280	56	100*100



平底固定

100074	4寸	64	100	50	-	143	270	405	115*100	-	84*71.3	11	20	460*260*280	56	100*100
100075	5寸	64	125	50	-	165.5	320	480	115*100	-	84*71.3	11	16	460*260*280	56	100*100
100076	6寸	64	150	50	-	190	430	645	115*100	-	84*71.3	11	12	460*260*280	56	100*100
100077	8寸	64	200	50	-	240.5	480	720	115*100	-	84*71.3	11	8	460*260*280	56	100*100



平底边刹

100224	4寸	64	100	50	-	143	270	405	115*100	83	84*71.3	11	15	460*260*280	56	100*100
100225	5寸	64	125	50	-	165.5	320	480	115*100	98	84*71.3	11	12	460*260*280	56	100*100
100226	6寸	64	150	50	-	190	430	645	115*100	114	84*71.3	11	8	460*260*280	56	100*100
100227	8寸	64	200	50	-	240.5	480	720	115*100	147	84*71.3	11	6	460*260*280	56	100*100



平底双刹

100179	4寸	64	100	50	-	143	270	405	115*100	83	84*71.3	11	15	460*260*280	56	100*100
100180	5寸	64	125	50	-	165.5	320	480	115*100	98	84*71.3	11	12	460*260*280	56	100*100
100181	6寸	64	150	50	-	190	430	645	115*100	114	84*71.3	11	8	460*260*280	56	100*100
100182	8寸	64	200	50	-	240.5	480	720	115*100	147	84*71.3	11	6	460*260*280	56	100*100

中型系列 Medium Series

02

适用于电子、纺织、机械设备、医疗等行业



Sectional View Animation

产品剖视图

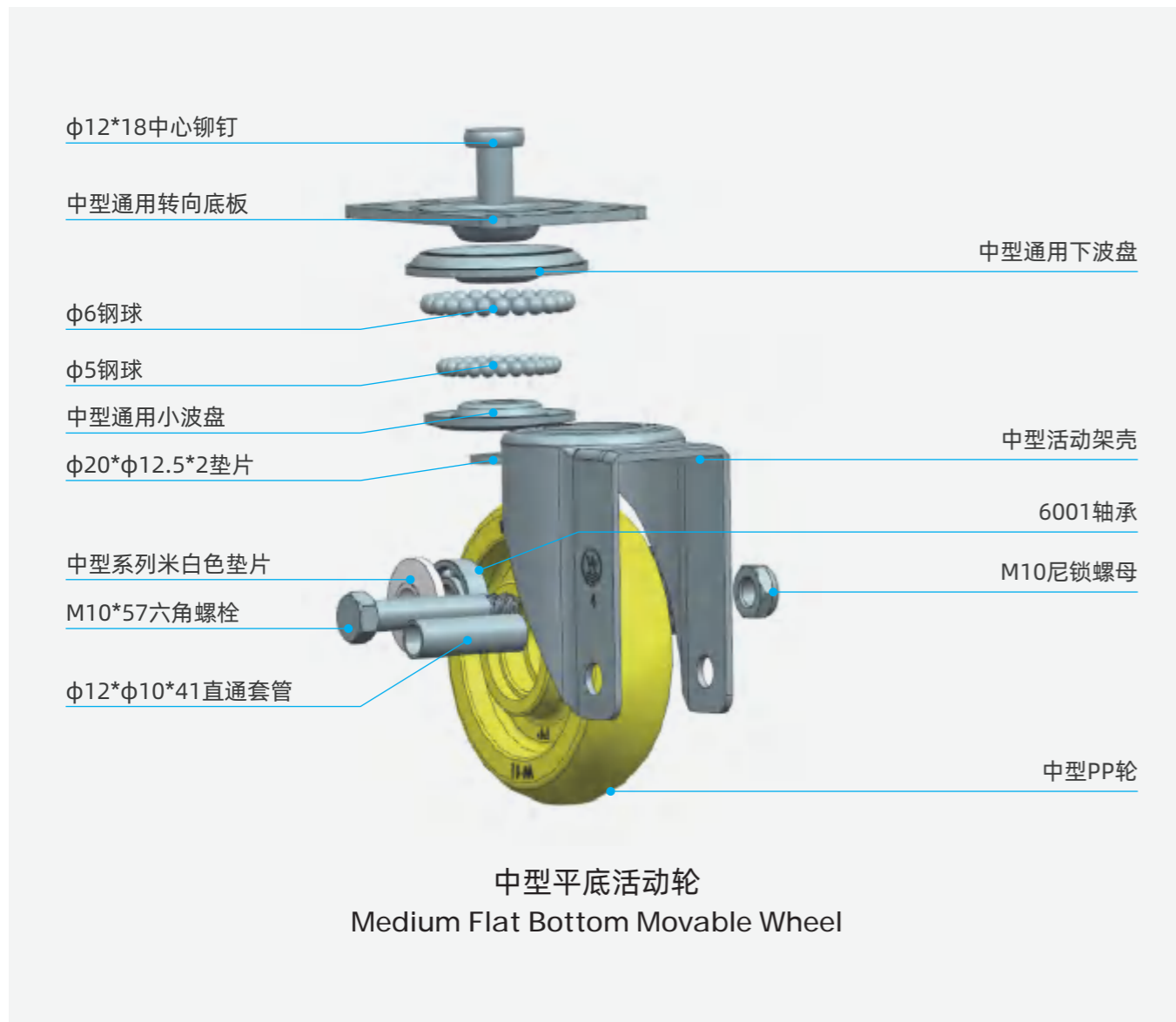

Installation Dimensions

安装尺寸图

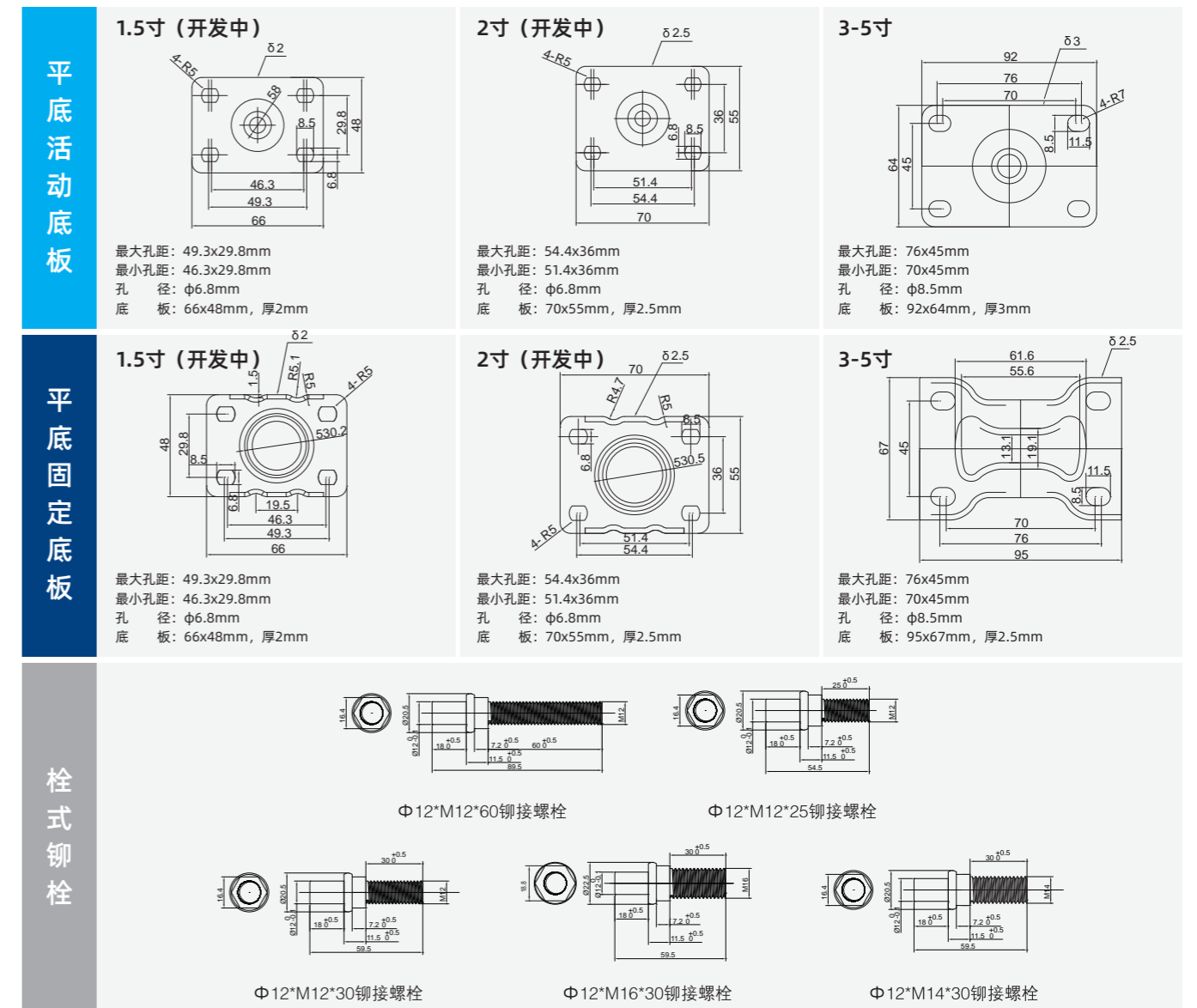

02-1 中型工程 共聚(增韧PP)轮系列

Medium Series Wheel

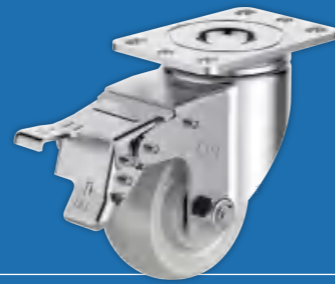

单轮剖视
双轴承工程共聚轮



产品特点



盐雾
级别
四级

耐磨

防油污

防老化

镀锌

四级

PRODUCT
TYPE

产品类型

No.

产品编码



支架尺寸

寸



丝长

mm



支架开口宽度

mm



轮径

mm



轮宽

mm



净重

kg



载重

kg



极限载重

kg



安装高度

kg



转动半径

mm



装箱数

个



装箱尺寸

mm



拖数

箱



托盘尺寸

mm



平底活动

100398	3	-	41	75	32	-	100	150	108.5	33	55	460*260*280	56	100*100
100399	4	-	41	100	32	-	130	195	136	33	40	460*260*280	56	100*100
100400	5	-	41	125	32	-	140	210	160.5	33	30	460*260*280	56	100*100



平底固定

100495	3	-	41	75	32	-	100	150	108.5	-	55	460*260*280	56	100*100
100496	4	-	41	100	32	-	130	195	136	-	40	460*260*280	56	100*100
100497	5	-	41	125	32	-	140	210	160.5	-	30	460*260*280	56	100*100



平底双刹

100407	3	-	41	75	32	-	100	150	108.5	33	45	460*260*280	56	100*100
100408	4	-	41	100	32	-	130	195	136	33	32	460*260*280	56	100*100
100409	5	-	41	125	32	-	140	210	160.5	33	25	460*260*280	56	100*100

02-1 中型工程 共聚(增韧PP)轮系列

Medium Series Wheel

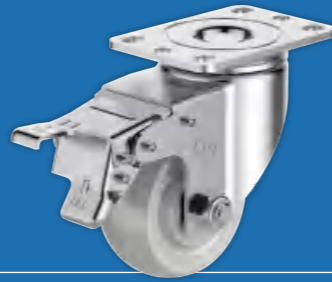

单轮剖视
双轴承工程共聚轮

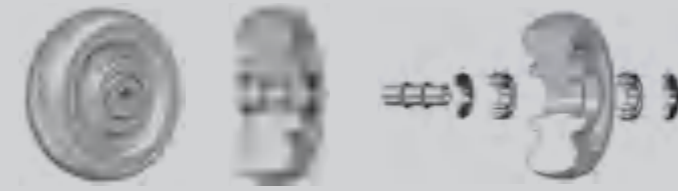

产品特点



耐磨

防油污

防老化

镀锌

盐雾
级别
四级

PRODUCT
TYPE

产品类型

No.

产品编码

⊙

支架尺寸

寸

⋮

丝长

mm

⏏

支架开口宽度

mm

⊙

轮径

mm

⋮

轮宽

mm

⚖

净重

kg

MIN

载重

kg

MAX

极限载重

kg

⏏

安装高度

kg

⏏

转动半径

mm

⏏

装箱数

个

⏏

装箱尺寸

mm

⏏

拖数

箱

⏏

托盘尺寸

mm



栓式活动

100416	3	M12*25	41	75	32	-	100	150	105	33	55	460*260*280	56	100*100
100425	3	M12*30	41	75	32	-	100	150	105	33	55	460*260*280	56	100*100
100434	3	M14*30	41	75	32	-	100	150	105	33	55	460*260*280	56	100*100
100443	3	M16*30	41	75	32	-	100	150	105	33	55	460*260*280	56	100*100
100417	4	M12*25	41	100	32	-	130	195	132.5	33	40	460*260*280	56	100*100
100426	4	M12*30	41	100	32	-	130	195	132.5	33	40	460*260*280	56	100*100
100435	4	M14*30	41	100	32	-	130	195	132.5	33	40	460*260*280	56	100*100
100444	4	M16*30	41	100	32	-	130	195	132.5	33	40	460*260*280	56	100*100
100418	5	M12*25	41	125	32	-	140	210	157	33	30	460*260*280	56	100*100
100427	5	M12*30	41	125	32	-	140	210	157	33	30	460*260*280	56	100*100
100436	5	M14*30	41	125	32	-	140	210	157	33	30	460*260*280	56	100*100
100445	5	M16*30	41	125	32	-	140	210	157	33	30	460*260*280	56	100*100



栓式双刹

100452	3	M12*25	41	75	32	-	100	150	105	33	45	460*260*280	56	100*100
100461	3	M12*30	41	75	32	-	100	150	105	33	45	460*260*280	56	100*100
100467	3	M14*30	41	75	32	-	100	150	105	33	45	460*260*280	56	100*100
100476	3	M16*30	41	75	32	-	100	150	105	33	45	460*260*280	56	100*100
100453	4	M12*25	41	100	32	-	130	195	132.5	33	32	460*260*280	56	100*100
100462	4	M12*30	41	100	32	-	130	195	132.5	33	32	460*260*280	56	100*100
100468	4	M14*30	41	100	32	-	130	195	132.5	33	32	460*260*280	56	100*100
100477	4	M16*30	41	100	32	-	130	195	132.5	33	32	460*260*280	56	100*100
100454	5	M12*25	41	125	32	-	140	210	157	33	25	460*260*280	56	100*100
100463	5	M12*30	41	125	32	-	140	210	157	33	25	460*260*280	56	100*100
100469	5	M14*30	41	125	32	-	140	210	157	33	25	460*260*280	56	100*100
100478	5	M16*30	41	125	32	-	140	210	157	33	25	460*260*280	56	100*100

02-1 中型工程 共聚(增韧PP)轮系列

Medium Series Wheel



单轮剖视
双轴承工程共聚轮

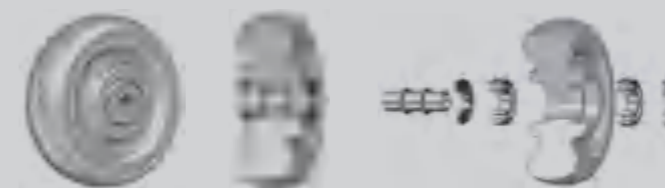

产品特点



PRODUCT TYPE

产品类型

No.

产品编码



支架尺寸



丝长



支架开口宽度



轮径



轮宽



净重



载重



极限载重



安装高度



转动半径



装箱数



装箱尺寸



拖数



托盘尺寸

寸

mm

mm

mm

mm

kg

kg

kg

kg

mm

个

mm

箱

mm



线棒款活动

100516	3	M12*60	41	75	32	-	100	150	105	33	55	460*260*280	56	100*100
100517	4	M12*60	41	100	32	-	130	195	132.5	33	40	460*260*280	56	100*100
100518	5	M12*60	41	125	32	-	140	210	157	33	30	460*260*280	56	100*100



线棒款双刹

100507	3	M12*60	41	75	32	-	100	150	105	33	45	460*260*280	56	100*100
100508	4	M12*60	41	100	32	-	130	195	132.5	33	32	460*260*280	56	100*100
100509	5	M12*60	41	125	32	-	140	210	157	33	25	460*260*280	56	100*100



膨胀套活动

100534	3	M12*60	41	75	32	-	100	150	105	33	55	460*260*280	56	100*100
100535	4	M12*60	41	100	32	-	130	195	132.5	33	40	460*260*280	56	100*100
100536	5	M12*60	41	125	32	-	140	210	157	33	30	460*260*280	56	100*100



膨胀套双刹

100525	3	M12*60	41	75	32	-	100	150	105	33	45	460*260*280	56	100*100
100526	4	M12*60	41	100	32	-	130	195	132.5	33	32	460*260*280	56	100*100
100527	5	M12*60	41	125	32	-	140	210	157	33	25	460*260*280	56	100*100

02-2 中型回弹 聚氨酯轮(耐磨配方)轮系列

Medium Series Wheel



单轮剖视
双轴承聚氨酯轮



产品特点



PRODUCT TYPE 产品类型	No. 产品编码	⊙ 支架尺寸 寸	∏ 丝长 mm	∏ 支架开口宽度 mm	⊙ 轮径 mm	∏ 轮宽 mm	⚖ 净重 kg	MIN 载重 kg	MAX 极限载重 kg	∏ 安装高度 kg	∏ 转动半径 mm	📦 装箱数 个	📦 装箱尺寸 mm	📦 拖数 箱	📦 托盘尺寸 mm
----------------------	-------------	----------------	---------------	-------------------	---------------	---------------	---------------	-----------------	-------------------	-----------------	-----------------	---------------	-----------------	--------------	-----------------



100401	3	-	41	75	32	-	100	150	108.5	33	55	460*260*280	56	100*100
100402	4	-	41	100	32	-	130	195	136	33	40	460*260*280	56	100*100
100403	5	-	41	125	32	-	140	210	160.5	33	30	460*260*280	56	100*100



100489	3	-	41	75	32	-	100	150	108.5	-	55	460*260*280	56	100*100
100490	4	-	41	100	32	-	130	195	136	-	40	460*260*280	56	100*100
100491	5	-	41	125	32	-	140	210	160.5	-	30	460*260*280	56	100*100



100410	3	-	41	75	32	-	100	150	108.5	33	45	460*260*280	56	100*100
100411	4	-	41	100	32	-	130	195	136	33	32	460*260*280	56	100*100
100412	5	-	41	125	32	-	140	210	160.5	33	25	460*260*280	56	100*100

02-2 中型回弹 聚氨酯轮(耐磨配方)轮系列

Medium Series Wheel



单轮剖视
双轴承聚氨酯轮



产品特点



PRODUCT TYPE

产品类型

No.

产品编码

⊙

支架尺寸

寸

∩

丝长

mm

∩

支架开口宽度

mm

⊙

轮径

mm

∩

轮宽

mm

∩

净重

kg

MIN

载重

kg

MAX

极限载重

kg

∩

安装高度

kg

∩

转动半径

mm

∩

装箱数

个

∩

装箱尺寸

mm

∩

拖数

箱

∩

托盘尺寸

mm



栓式活动

100419	3	M12*25	41	75	32	-	100	150	105	33	55	460*260*280	56	100*100
100428	3	M12*30	41	75	32	-	100	150	105	33	55	460*260*280	56	100*100
100437	3	M14*30	41	75	32	-	100	150	105	33	55	460*260*280	56	100*100
100446	3	M16*30	41	75	32	-	100	150	105	33	55	460*260*280	56	100*100
100420	4	M12*25	41	100	32	-	130	195	132.5	33	40	460*260*280	56	100*100
100429	4	M12*30	41	100	32	-	130	195	132.5	33	40	460*260*280	56	100*100
100438	4	M14*30	41	100	32	-	130	195	132.5	33	40	460*260*280	56	100*100
100447	4	M16*30	41	100	32	-	130	195	132.5	33	40	460*260*280	56	100*100
100421	5	M12*25	41	125	32	-	140	210	157	33	30	460*260*280	56	100*100
100430	5	M12*30	41	125	32	-	140	210	157	33	30	460*260*280	56	100*100
100439	5	M14*30	41	125	32	-	140	210	157	33	30	460*260*280	56	100*100
100448	5	M16*30	41	125	32	-	140	210	157	33	30	460*260*280	56	100*100



栓式双刹

100455	3	M12*25	41	75	32	-	100	150	105	33	45	460*260*280	56	100*100
100486	3	M12*30	41	75	32	-	100	150	105	33	45	460*260*280	56	100*100
100470	3	M14*30	41	75	32	-	100	150	105	33	45	460*260*280	56	100*100
100479	3	M16*30	41	75	32	-	100	150	105	33	45	460*260*280	56	100*100
100456	4	M12*25	41	100	32	-	130	195	132.5	33	32	460*260*280	56	100*100
100487	4	M12*30	41	100	32	-	130	195	132.5	33	32	460*260*280	56	100*100
100471	4	M14*30	41	100	32	-	130	195	132.5	33	32	460*260*280	56	100*100
100480	4	M16*30	41	100	32	-	130	195	132.5	33	32	460*260*280	56	100*100
100457	5	M12*25	41	125	32	-	140	210	157	33	25	460*260*280	56	100*100
100488	5	M12*30	41	125	32	-	140	210	157	33	25	460*260*280	56	100*100
100472	5	M14*30	41	125	32	-	140	210	157	33	25	460*260*280	56	100*100
100481	5	M16*30	41	125	32	-	140	210	157	33	25	460*260*280	56	100*100

02-2 中型回弹 聚氨酯轮(耐磨配方)轮系列

Medium Series Wheel



双轴承聚氨酯轮



产品特点



PRODUCT TYPE

产品类型

No.

产品编码



支架尺寸



丝长



支架开口宽度



轮径



轮宽



净重



载重



极限载重



安装高度



转动半径



装箱数



装箱尺寸



拖数



托盘尺寸

寸

mm

mm

mm

mm

kg

kg

kg

kg

mm

个

mm

箱

mm



线棒款活动

100513	3	M12*60	41	75	32	-	100	150	105	33	55	460*260*280	56	100*100
100514	4	M12*60	41	100	32	-	130	195	132.5	33	40	460*260*280	56	100*100
100515	5	M12*60	41	125	32	-	140	210	157	33	30	460*260*280	56	100*100



线棒款双刹

100504	3	M12*60	41	75	32	-	100	150	105	33	45	460*260*280	56	100*100
100505	4	M12*60	41	100	32	-	130	195	132.5	33	32	460*260*280	56	100*100
100506	5	M12*60	41	125	32	-	140	210	157	33	25	460*260*280	56	100*100



膨胀套活动

100531	3	M12*60	41	75	32	-	100	150	105	33	55	460*260*280	56	100*100
100532	4	M12*60	41	100	32	-	130	195	132.5	33	40	460*260*280	56	100*100
100533	5	M12*60	41	125	32	-	140	210	157	33	30	460*260*280	56	100*100



膨胀套双刹

100522	3	M12*60	41	75	32	-	100	150	105	33	45	460*260*280	56	100*100
100523	4	M12*60	41	100	32	-	130	195	132.5	33	32	460*260*280	56	100*100
100524	5	M12*60	41	125	32	-	140	210	157	33	25	460*260*280	56	100*100

02-3 中型塑芯 高分子TPR(Q弹配方)轮系列

Medium Series Wheel



单轮剖视
高分子TPR轮



产品特点



PRODUCT TYPE 产品类型	No. 产品编码	支架尺寸 寸	丝长 mm	支架开口宽度 mm	轮径 mm	轮宽 mm	净重 kg	MIN 载重 kg	MAX 极限载重 kg	安装高度 kg	转动半径 mm	装箱数 个	装箱尺寸 mm	拖数 箱	托盘尺寸 mm
----------------------	-------------	-----------	----------	--------------	----------	----------	----------	-----------------	-------------------	------------	------------	----------	------------	---------	------------



100404	3	-	41	75	32	-	100	150	108.5	33	55	460*260*280	56	100*100
100405	4	-	41	100	32	-	130	195	136	33	40	460*260*280	56	100*100
100406	5	-	41	125	32	-	140	210	160.5	33	30	460*260*280	56	100*100



100492	3	-	41	75	32	-	100	150	108.5	-	55	460*260*280	56	100*100
100493	4	-	41	100	32	-	130	195	136	-	40	460*260*280	56	100*100
100494	5	-	41	125	32	-	140	210	160.5	-	30	460*260*280	56	100*100



100413	3	-	41	75	32	-	100	150	108.5	33	45	460*260*280	56	100*100
100414	4	-	41	100	32	-	130	195	136	33	32	460*260*280	56	100*100
100415	5	-	41	125	32	-	140	210	160.5	33	25	460*260*280	56	100*100

02-3 中型塑芯 高分子TPR(Q弹配方)轮系列

Medium Series Wheel



单轮剖视
高分子TPR轮



产品特点



PRODUCT TYPE

产品类型

No.

产品编码

⊙

支架尺寸

寸

∩

丝长

mm

∩

支架开口宽度

mm

⊙

轮径

mm

∩

轮宽

mm

∩

净重

kg

MIN

载重

kg

MAX

极限载重

kg

∩

安装高度

kg

∩

转动半径

mm

∩

装箱数

个

∩

装箱尺寸

mm

∩

拖数

箱

∩

托盘尺寸

mm



栓式活动

100422	3	M12*25	41	75	32	-	100	150	105	33	55	460*260*280	56	100*100
100431	3	M12*30	41	75	32	-	100	150	105	33	55	460*260*280	56	100*100
100440	3	M14*30	41	75	32	-	100	150	105	33	55	460*260*280	56	100*100
100449	3	M16*30	41	75	32	-	100	150	105	33	55	460*260*280	56	100*100
100423	4	M12*25	41	100	32	-	130	195	132.5	33	40	460*260*280	56	100*100
100432	4	M12*30	41	100	32	-	130	195	132.5	33	40	460*260*280	56	100*100
100441	4	M14*30	41	100	32	-	130	195	132.5	33	40	460*260*280	56	100*100
100450	4	M16*30	41	100	32	-	130	195	132.5	33	40	460*260*280	56	100*100
100424	5	M12*25	41	125	32	-	140	210	157	33	30	460*260*280	56	100*100
100433	5	M12*30	41	125	32	-	140	210	157	33	30	460*260*280	56	100*100
100442	5	M14*30	41	125	32	-	140	210	157	33	30	460*260*280	56	100*100
100451	5	M16*30	41	125	32	-	140	210	157	33	30	460*260*280	56	100*100



栓式双刹

100458	3	M12*25	41	75	32	-	100	150	105	33	45	460*260*280	56	100*100
100464	3	M12*30	41	75	32	-	100	150	105	33	45	460*260*280	56	100*100
100473	3	M14*30	41	75	32	-	100	150	105	33	45	460*260*280	56	100*100
100482	3	M16*30	41	75	32	-	100	150	105	33	45	460*260*280	56	100*100
100459	4	M12*25	41	100	32	-	130	195	132.5	33	32	460*260*280	56	100*100
100465	4	M12*30	41	100	32	-	130	195	132.5	33	32	460*260*280	56	100*100
100474	4	M14*30	41	100	32	-	130	195	132.5	33	32	460*260*280	56	100*100
100483	4	M16*30	41	100	32	-	130	195	132.5	33	32	460*260*280	56	100*100
100460	5	M12*25	41	125	32	-	140	210	157	33	25	460*260*280	56	100*100
100466	5	M12*30	41	125	32	-	140	210	157	33	25	460*260*280	56	100*100
100475	5	M14*30	41	125	32	-	140	210	157	33	25	460*260*280	56	100*100
100484	5	M16*30	41	125	32	-	140	210	157	33	25	460*260*280	56	100*100

02-3 中型塑芯 高分子TPR(Q弹配方)轮系列

Medium Series Wheel



单轮剖视
高分子TPR轮



产品特点



PRODUCT TYPE

产品类型

No.

产品编码



支架尺寸



丝长



支架开口宽度



轮径



轮宽



净重



载重



极限载重



安装高度



转动半径



装箱数



装箱尺寸



拖数



托盘尺寸

寸

mm

mm

mm

mm

kg

kg

kg

kg

mm

个

mm

箱

mm



线棒款活动

100519	3	M12*60	41	75	32	-	100	150	105	33	16	460*260*280	56	100*100
100520	4	M12*60	41	100	32	-	130	195	132.5	33	12	460*260*280	56	100*100
100521	5	M12*60	41	125	32	-	140	210	157	33	12	460*260*280	56	100*100



线棒款双刹

100510	3	M12*60	41	75	32	-	100	150	105	33	12	460*260*280	56	100*100
100511	4	M12*60	41	100	32	-	130	195	132.5	33	12	460*260*280	56	100*100
100512	5	M12*60	41	125	32	-	140	210	157	33	8	460*260*280	56	100*100



膨胀套活动

100537	3	M12*60	41	75	32	-	100	150	105	33	16	460*260*280	56	100*100
100538	4	M12*60	41	100	32	-	130	195	132.5	33	12	460*260*280	56	100*100
100539t	5	M12*60	41	125	32	-	140	210	157	33	12	460*260*280	56	100*100



膨胀套双刹

100528	3	M12*60	41	75	32	-	100	150	105	33	12	460*260*280	56	100*100
100529	4	M12*60	41	100	32	-	130	195	132.5	33	12	460*260*280	56	100*100
100530	5	M12*60	41	125	32	-	140	210	157	33	8	460*260*280	56	100*100

气胎轮系列 Pneumatic Tire Series 03



Sectional View Animation

产品剖视图



Installation Dimensions

安装尺寸图

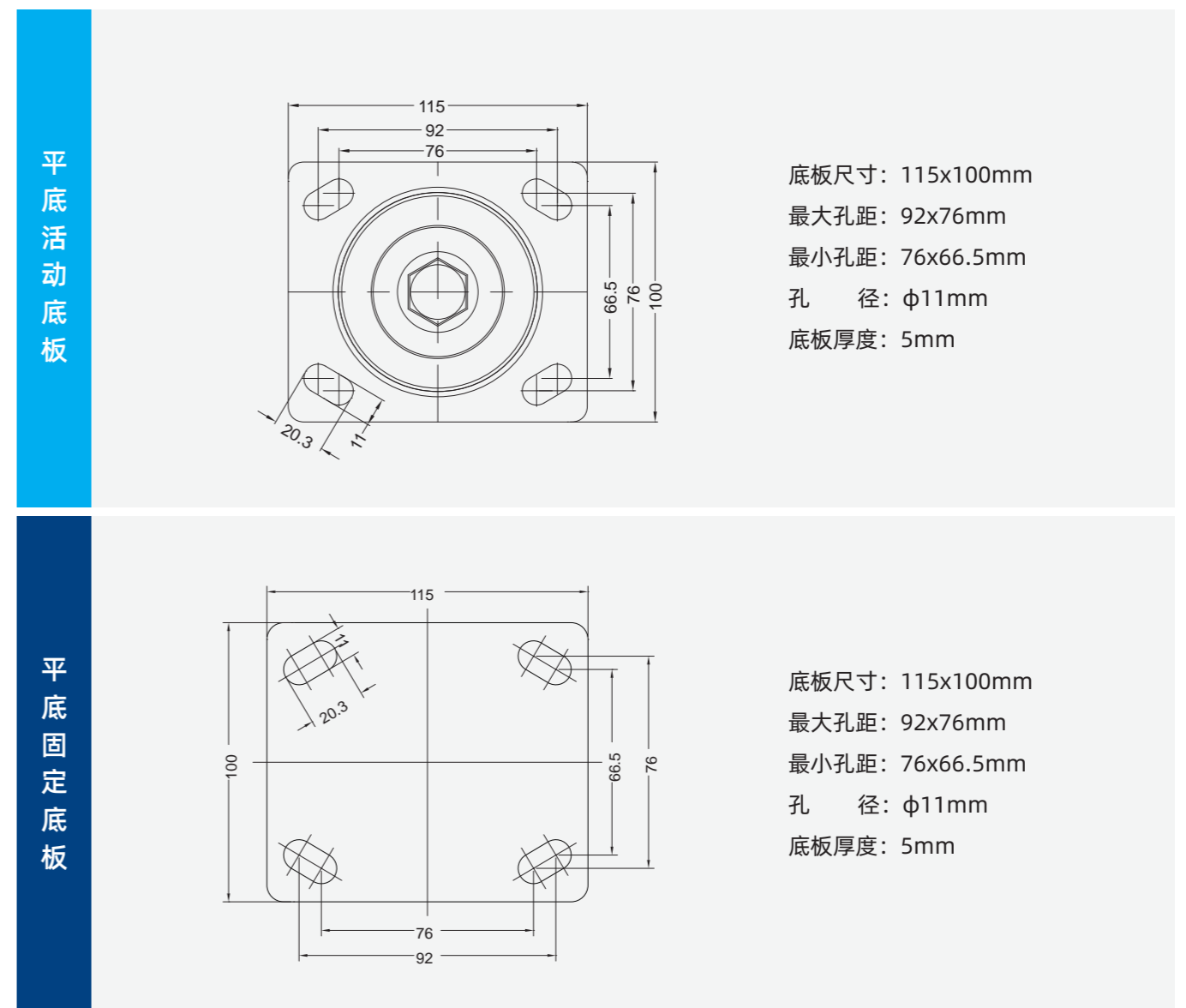

03-1 空气气胎轮系列

Pneumatic Tire Series



单轮剖视
双轴承空气气胎轮



产品特点



PRODUCT TYPE

产品类型

No.

产品编码



支架尺寸



支架开口宽度



轮径



轮宽



净重



安装高度



载重



极限载重



底板规格



转动半径



孔距



孔径



装箱数



装箱尺寸



拖数



托盘尺寸

寸

mm

mm

mm

kg

kg

kg

kg

mm

mm

mm

mm

个

mm

箱

mm



平底固定

100312

8

90

200

60

-

250

125

187.5

115*100

-

84*71.3

11

2

460*260*280

56

100*100

100308

10

104.5

250

82

-

308

150

225

115*100

-

84*71.3

11

2

460*260*280

56

100*100



平底活动

100311

8

90

200

60

-

250

125

187.5

115*100

150

84*71.3

11

2

460*260*280

56

100*100

100309

10

104.5

250

82

-

308

150

225

115*100

185

84*71.3

11

2

460*260*280

56

100*100



平底边刹

100310

8

90

200

60

-

250

125

187.5

115*100

150

84*71.3

11

2

460*260*280

56

100*100

地刹器系列 Brake Series

04



Sectional View Animation

动画剖视图

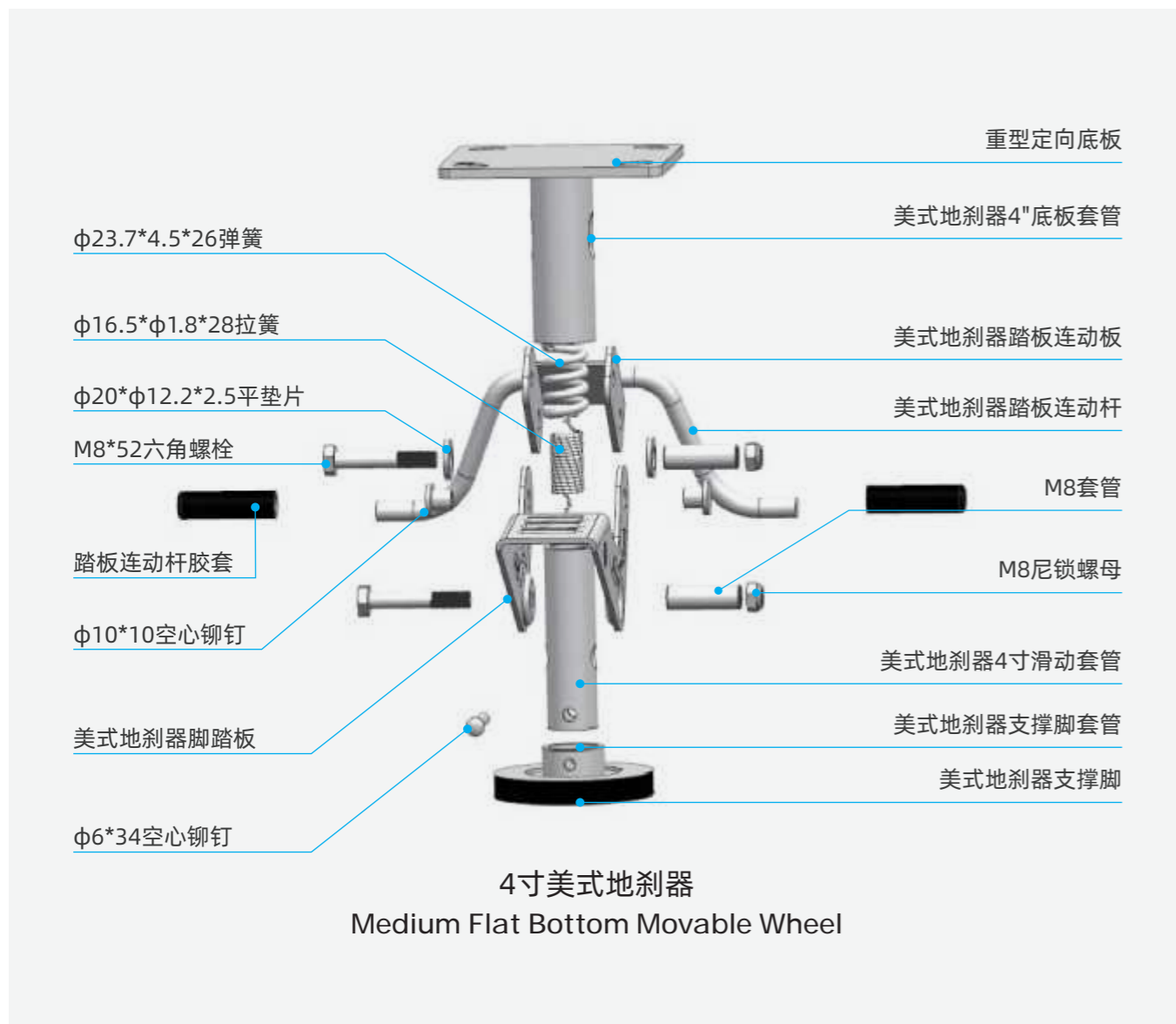

Installation Dimensions

安装尺寸图

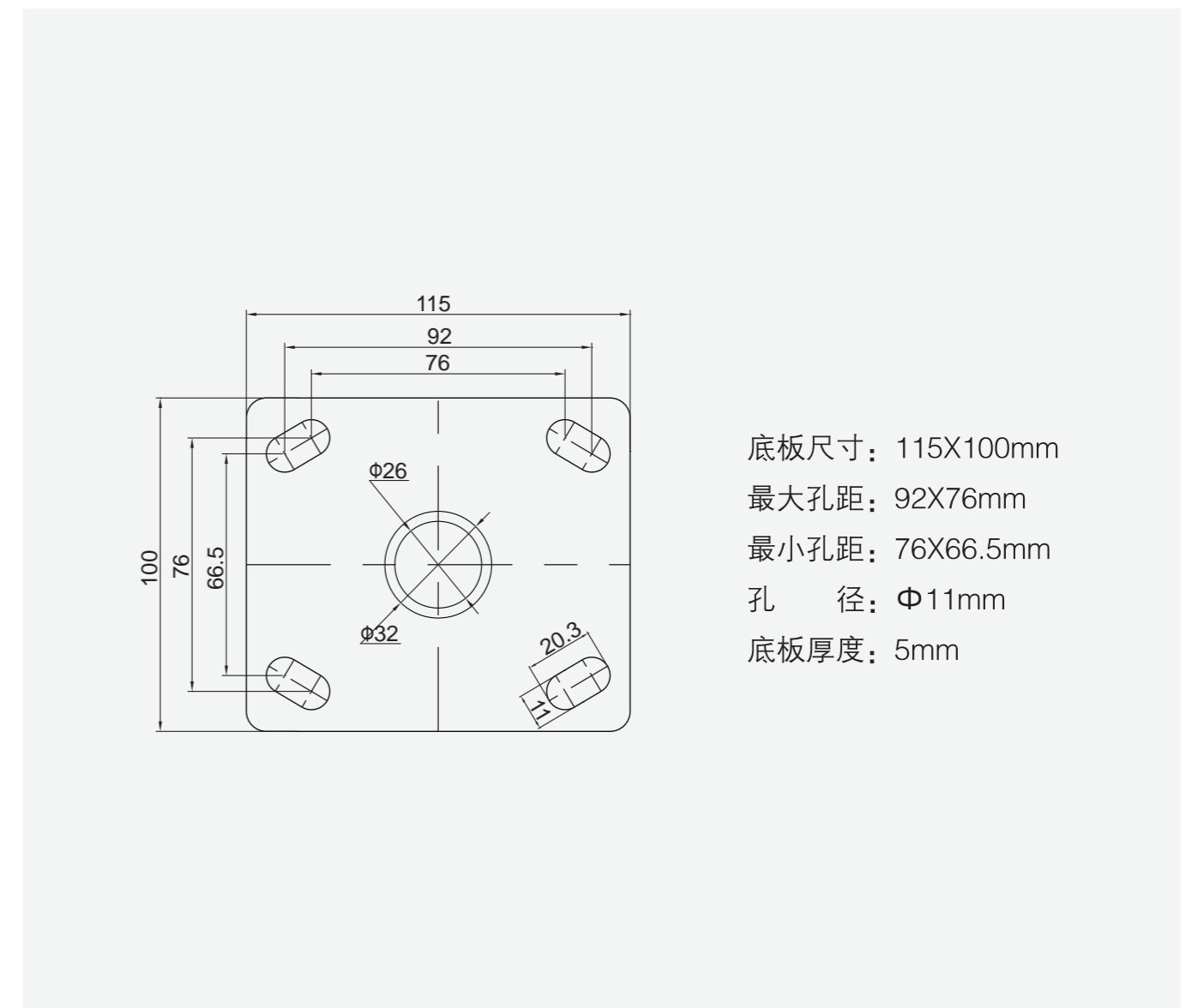

04-1 地刹器系列

Brake Series

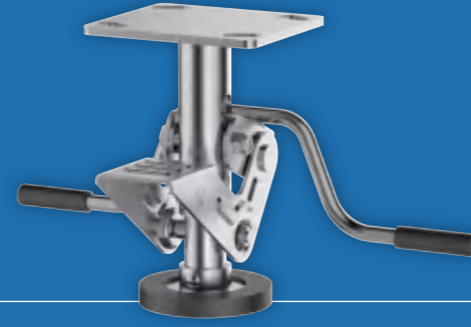

Business Negotiation

商务洽谈

时光荏苒,仰仗社会各界朋友的信赖与支持,伟海并得以不断成长、壮大。只有以质取胜,方能屹立不倒。我们将始终坚持与每位合作伙伴真诚携手,共同打造属于中国的世界级脚轮品牌。



▲ 2020年10月份第一届经销商品牌订购会



▲ 2021年2月20日, 海尔集团卡奥斯智慧能源张院长一行莅临公司参观洽谈。



▲ 2019年, 青岛海容商用冷链股份有限公司董事长邵伟一行人, 深入生产车间现场考察。



▲ 2020年9月, 北方脚轮工业互联网智汇发展论坛暨伟海科技战略合作伙伴揭牌签约仪式。



▲ 2019年8月, 伟海科技与山东交通学院达成产学研合作基地。



PRODUCT TYPE 产品类型	产品编码	支架尺寸 寸	伸展高度 mm	压缩高度 mm	净重 mm	载重 kg
美式地刹器4"总成	100267	4	150	122	-	300
美式地刹器5"总成	100268	5	176	150	-	350
美式地刹器6"总成	100269	6	200	173	-	400
美式地刹器8"总成	100270	8	245	219	-	500

PRODUCT TYPE 产品类型	产品编码	装箱数 箱	装箱尺寸 mm	拖数 箱	托架尺寸 mm	安装定位尺寸 mm
美式地刹器4"总成	100267	12	460*260*280	56	100*100	76*76
美式地刹器5"总成	100268	10	460*260*280	56	100*100	76*76
美式地刹器6"总成	100269	10	460*260*280	56	100*100	76*76
美式地刹器8"总成	100270	8	460*260*280	56	100*100	76*76

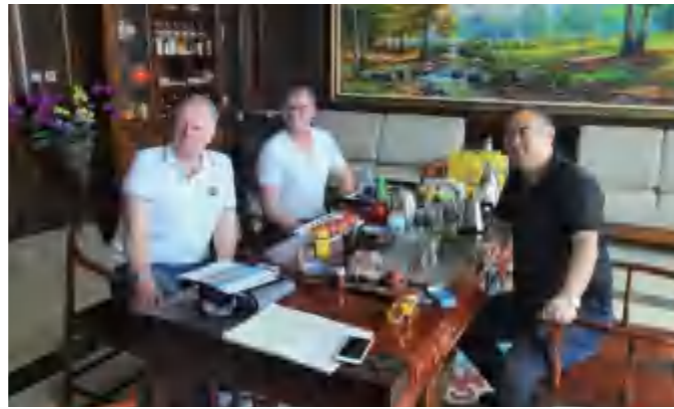

▲ 2019年，荷兰最大花架车经销商莅临我公司洽谈全年度花车采购计划。



▲ 2018年，与德国货架客户商务洽谈，同年达成合作订单。



▲ 2018年，比利时客户领略青岛啤酒节传统文化，把酒言欢，开怀畅饮。

科技创伟海 智造赢未来

TECHNOLOGY CREATE THE FUTURE